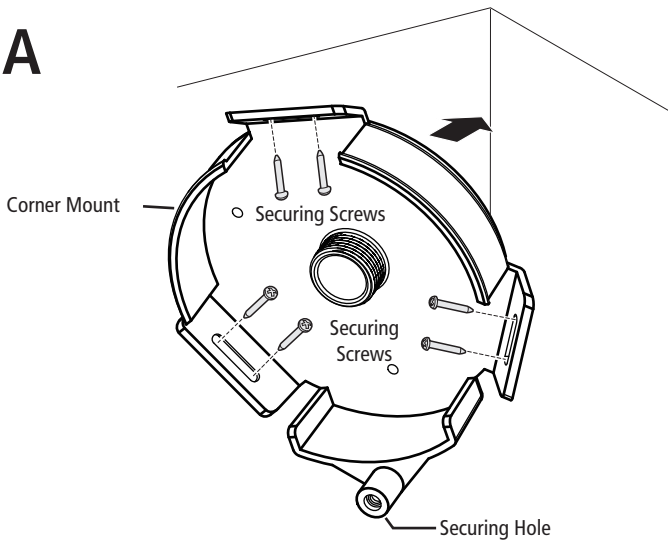
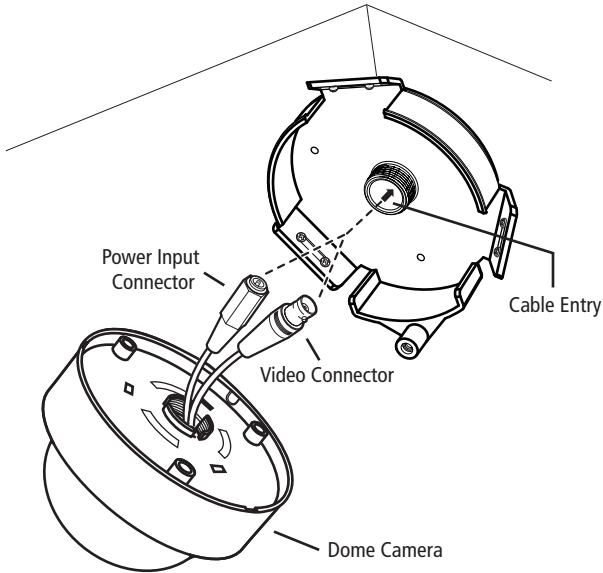

**A**

Locate the corner mount in the required position. Use screws and wall plugs (as appropriate to the wall surfaces) to fix the corner mount on the wall. Access to the screw positions is gained through the open front aperture of the corner mount.

**Note:** The securing hole should be on the bottom side of the corner mount (as picture shown above).

**B**

Install the dome camera on the corner mount by first arranging the cables.

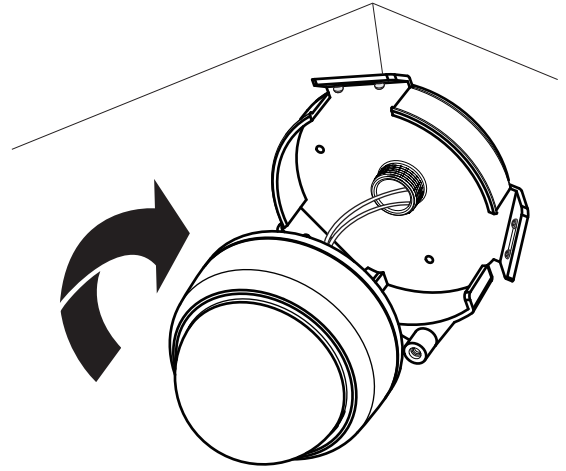
**C**

Fit and tighten the dome camera on the corner mount by rotating clockwise.

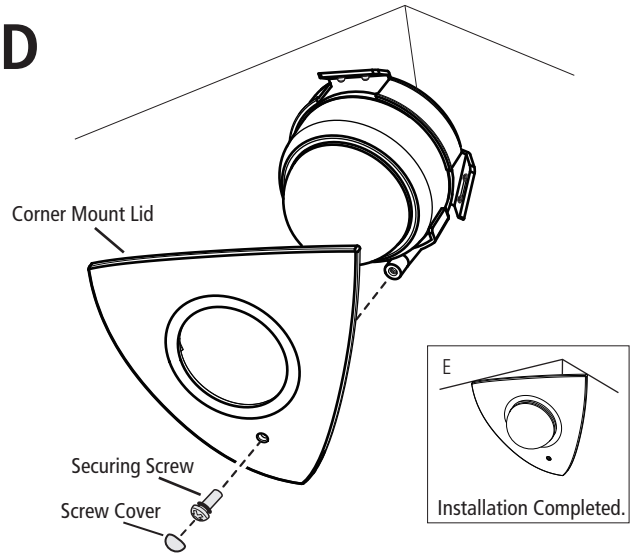
**D**

Cover the dome camera with the corner mount lid. Insert and tighten the securing screw to fix the lid to the corner mount. Insert the white screw cover to complete the installation.

**Note:** The lid is designed so that when placed on the base it has some free movement to try and compensate for un-even walls.

**AD AMERICAN DYNAMICS**

ADCPWMCRNR  
Indoor Mini Dome  
Corner Mount Installation Sheet

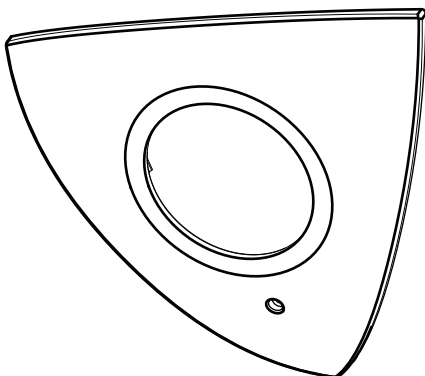

The ADCPWMCRNR Corner Mount is designed for use with all Discover Indoor Mini-Domes.

**Packing List**

- Corner Mount x 1
- Corner Mount Lid x 1
- Screw Pack x 1



Please visit our website for more information:

[www.americandynamics.net](http://www.americandynamics.net)

© 2007 Sensormatic Electronics Corporation.

Product specifications subject to change without notice. Certain product names mentioned herein may be trade names and/or registered trademarks of other companies.

8200-0865-01 Rev A

# Dimensions of Corner Mount

## Corner Mount Lid

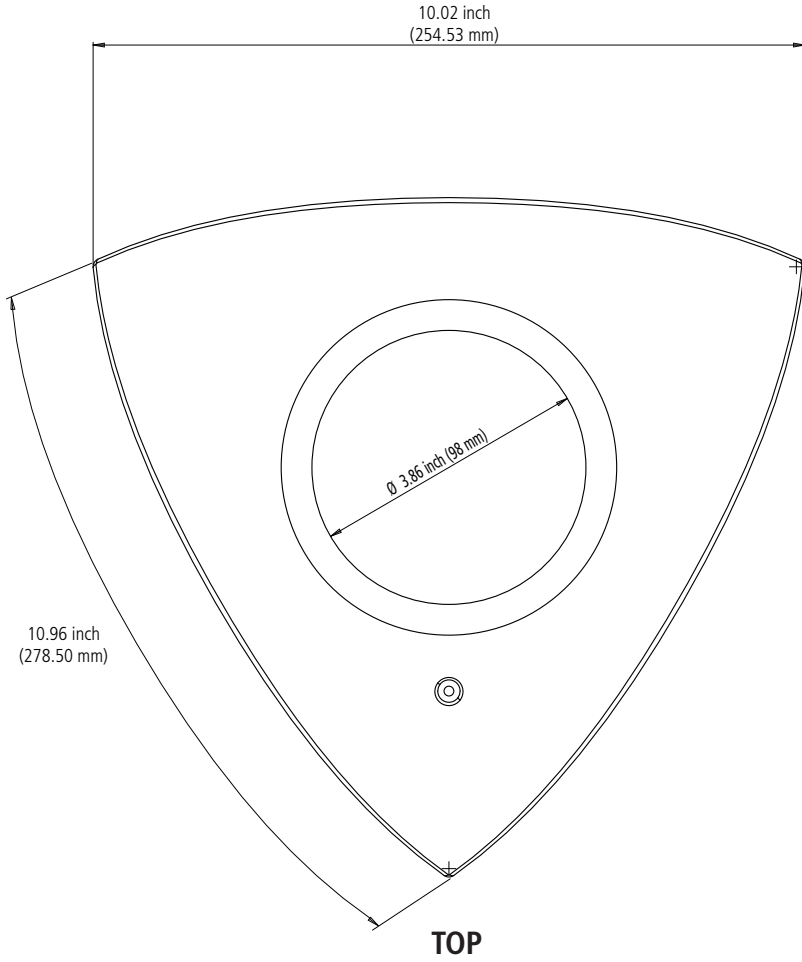

Color : RAL 9003  
 Material: Polycarbonate  
 Unit Weight : 9.02 oz (255.7g)  
 Base : 3.39 oz ( 96.2 g) Lid : 5.63 oz (159.5 g)  
 Shipping Weight (Per Piece) : 17.75 oz (503.2 g)

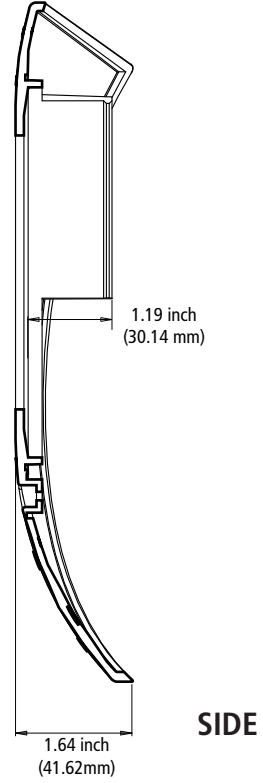

## Corner Mount Base

